

PROPRIETARY NOTICE:  
 THIS DOCUMENT AND THE ACCOMPANYING DATA ARE NOT TO BE REPRODUCED, USED BY OR DISCLOSED TO ANYONE, BUT THE CUSTOMER OF SAID DEVICE, IN WHOLE OR IN PART WITHOUT THE EXPRESS CONSENT OF INFRARED ASSOCIATES, INC..

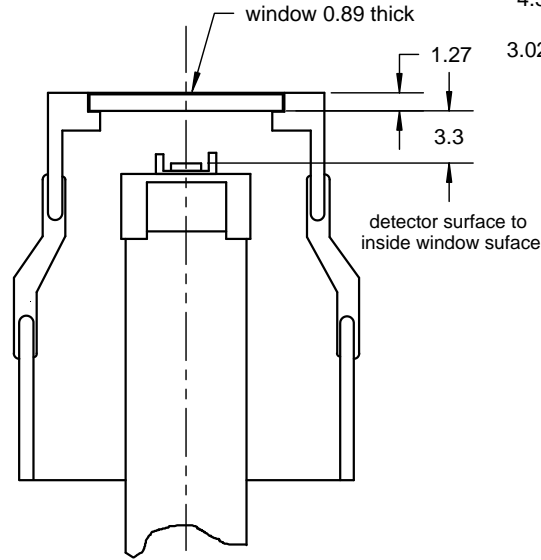

3.075 dia. +/- .015  
 x 6.0 DP  
 4.5 dia. mounting  
 holes 3PL  
 3.021 dia. +/- .007  
 x 6.0 DP

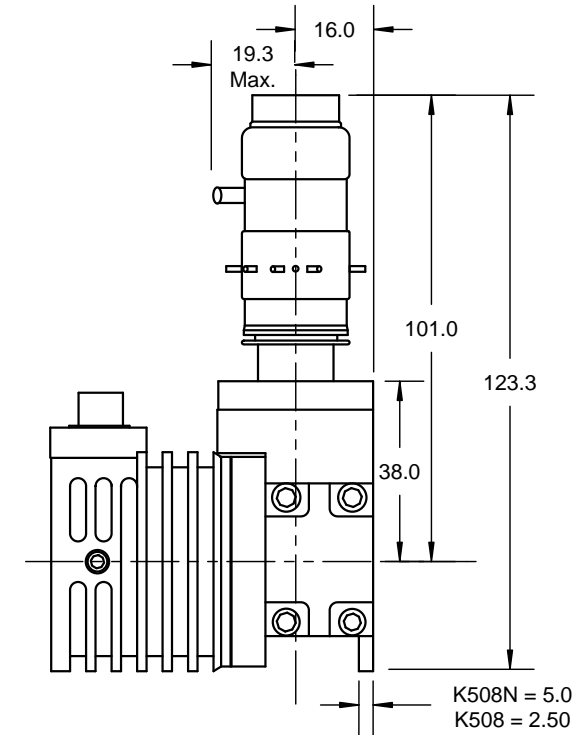
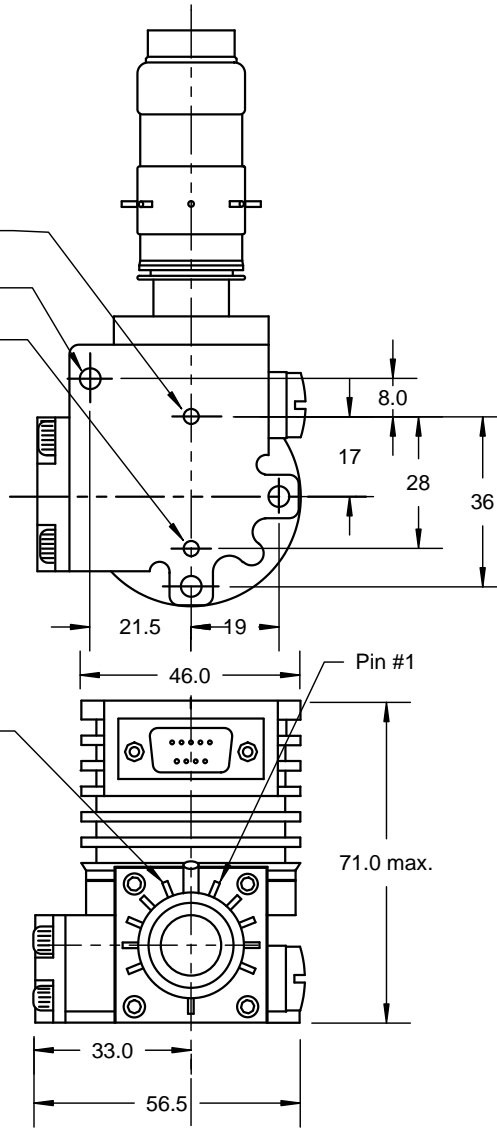

DIMENSIONS UNLESS OTHERWISE SPECIFIED ARE IN MM.  
 TOLERANCES:  
 FRACTIONS: +/- 1/64, ANGLES +/- 0.5 DEGREES.  
 3 PLACE DECIMALS +/- 0.005  
 2 PLACE DECIMALS +/- 0.02

MATERIAL  
 SEE NOTES

FINISH  
 N.A.

DO NOT SCALE		EUROPE PROJECTION	
PREPARED	BY: F. W. Rothe	07/01/2003	
CHECKED	A. Lucidi	09/04/2003	
ENGINEERING			
PRODUCTION			
QUALITY			
SCALE: N.A.	SHEET 1	OF 1	
JOB NO.	NEXT ASSY		

<b>Infrared Associates, Inc.</b> Stuart, Florida 34997			
K-508(N) Detector Assembly, Extended			
SIZE	FSCM NO.	DRAWING NO.	REV
A	15737		